

# DT-105A-S12 (LCD)

# DT-107A-S12 (LED)

## Superior accuracy in high speed measurement

Possessing the same sophisticated features and accessories as our renowned DT-105A/107A models, the DT-105A-S12 and DT-107A-S12 tachometers provide outstanding accuracy in measuring speed and direct linear length via a 12" wheel. The larger wheel rotates more slowly than a standard 6" wheel, thus enabling confident and safe high speed measurement.

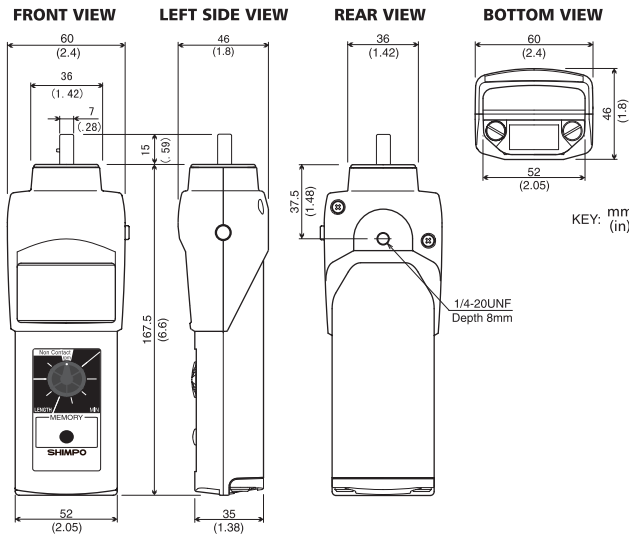

## Specifications

<b>MODEL</b>	<b>DT-105A-S12 / DT-107A-S12</b>
<b>MEASURING RANGE</b>	0.10 - 25,000 rpm with floating decimal
<b>ACCURACY</b>	±0.06 rpm : 0.10 - 999.9 rpm / ±0.6 rpm : 1,000.0 - 9,999.9 rpm / ±0.006 % of reading ±1 digit (or 2 rpm max.) : 10,000 - 25,000 rpm
<b>DISPLAY</b>	5 digit 0.47" (12 mm) high LCD      5 digit 0.4" (10 mm) high LED
<b>MEASURING UNITS</b>	Revolutions : rpm, rpm    Feet : fph, fph    Miles : mph Yards : yph, ypm    Inches : ipm    Meters : mPM, mPM Length : m, cm, inches, feet, yards    Total Revolutions : REV
<b>MEMORY</b>	13 readings are stored in memory and retained for 5 minutes (last, max., min. and 10 extra measurements)
<b>DISPLAY UPDATE TIME</b>	1 second (typical)
<b>DETECTION</b>	Optical coupler, 60 pulses/rev.
<b>SYSTEM CONTROL</b>	Single-chip C-MOS microprocessor
<b>OVER RANGE INDICATOR</b>	Flashing numerals
<b>VOLTAGE REQUIREMENT</b>	2 AA 1.5 V batteries
<b>LOW BATTERY INDICATOR</b>	Flashing "LO BAT" display      "B" display (DT-107A-S12)
<b>AUTO POWER SHUT-OFF</b>	Yes
<b>BATTERY LIFE</b>	40-60 hrs approx.    25 hrs approx. (DT-107A-S12)
<b>OPERATING TEMP. RANGE</b>	32° - 113° F (0 - 45° C)
<b>OPERATING ENVIRONMENT</b>	Non corrosive
<b>DECIMAL POINT</b>	Floating
<b>CONSTRUCTION</b>	Die-cast aluminum housing
<b>WEIGHT</b>	0.9 lb (400 g)
<b>DIMENSIONS</b>	7.2" L x 2.4" W x 1.8" H (182.5 mm x 60 mm x 46 mm)
<b>WARRANTY</b>	1 year
<b>STANDARD ACCESSORIES</b>	2 cone adapters, funnel adapter, 3-1/2" extension shaft, NIST certificate, carrying case, master wheel (12" cir.)
<b>OPTIONAL ACCESSORIES</b>	FPM-12CBL / 12" grooved wheel

## Features

- 12" circumference wheel
- 1/4 x 20 mounting hole
- Multi-mode speed selection
- Outstanding accuracy (±0.006% of reading)
- Rugged aluminum construction
- Direct length measurement
- Extensive speed range (0.10 - 25,000 RPM)
- Large 5 digit display
- Length/ sec available
- Large 10 test memory capacity; plus LAST, MAX and MIN
- Total revolution display
- Free N.I.S.T. certificate
- CE mark
- Overspeed indicator



DT-107A-S12 shown in carrying case, with 12" circumference wheel

DISTRIBUTED BY

**commtest**  
Southern Africa

419 Vine Avenue, Ferndale, Johannesburg  
P.O. Box 1669, Ferndale, South Africa, 2160  
Tel: +27 11 886 7993, web: www.commtest.co.za  
Fax: +27 11 507 5823, email: info@commtest.co.za