

DT-205L (LCD)

DT-207L (LED)

Laser-enabled precise RPM measurement up to 14 feet

Our DT-205L and DT-207L tachometers incorporate laser technology yet retain our hallmark rugged construction and reliable quality components; both offer incredible value and versatility as they perform non-contact and contact applications via the included contact adapter.

We're confident you'll agree that these fine units are the most advanced handheld tachometers on the market!

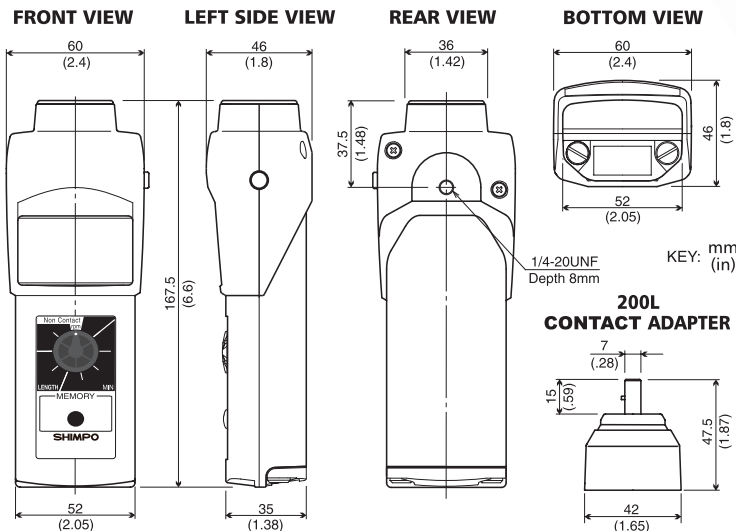

Specifications

| MODEL | DT-205L / DT-207L |
|------------------------------|---|
| MEASURING RANGE | 6 - 99,999 rpm |
| ACCURACY | ±1 rpm: 6 - 8,300 rpm / ±2 rpm: 8,301 - 25,000 rpm / ±0.006 % of reading ±1 digit (or 2 rpm max.): 25,001 - 99,999 rpm |
| DISPLAY | 5 digit 0.47" (12 mm) high LCD / 5 digit 0.4" (10 mm) high LED |
| MEASURING UNITS | rpm (using contact adapter, included) For rate: ypm, mPM, fpm, ipm & length: yd, m, ft, in, use 6" cir. wheel w/ 200L contact adapter |
| MEMORY | 13 readings are stored in memory & retained for 5 minutes (last, max., min. and 10 extra measurements) |
| DISPLAY UPDATE TIME | 1 second (typical) |
| DETECTION | Laser diode |
| SYSTEM CONTROL | Single-chip C-MOS microprocessor |
| OVER RANGE INDICATOR | Flashing numerals |
| VOLTAGE REQUIREMENT | 2 AA 1.5 V batteries |
| LOW BATTERY INDICATOR | Flashing "LO BAT" display / "B" display (DT-207L) |
| AUTO POWER SHUT-OFF | Yes |
| BATTERY LIFE | 40-60 hrs approx. / 25 hrs approx. (DT-207L) |
| OPERATING TEMP. RANGE | 32° - 113° F (0 - 45° C) |
| OPERATING ENVIRONMENT | Non corrosive |
| CONSTRUCTION | Die-cast aluminum housing |
| WEIGHT | 0.8 lb (365 g) |
| DIMENSIONS | 6.6" L x 2.4" W x 1.8" H (167.5 mm x 60 mm x 46 mm) |
| WARRANTY | 1 year |
| STANDARD ACCESSORIES | Reflective tape, 2 cone adapters, funnel adapter, 3½" extension shaft, carrying case, NIST certificate, master wheel (6" cir.) & 200L contact adapter |

Features

- 1/4 x 20 mounting hole
- Sophisticated laser beam detection; up to 14'
- Exceptional accuracy
- Length and rate functions
- Length/ sec available
- Broad speed range
- Hardy aluminum construction
- Large 5 digit display
- Expansive 10 test memory capacity
- Extended battery life
- Free N.I.S.T. certificate
- CE mark

Also Available



DT-205L shown in carrying case.
Models: DT-205L-S12 & DT-207L-S12
w/ 12" master wheel.

DISTRIBUTED BY

commtest
Southern Africa

419 Vine Avenue, Ferndale, Johannesburg
P.O. Box 1669, Ferndale, South Africa, 2160
Tel: +27 11 886 7993, web: www.commtest.co.za
Fax: +27 11 507 5823, email: info@commtest.co.za